

MODEL POW 35-5
BIPOLAR POWER
SUPPLY/AMPLIFIER
INSTRUCTION MANUAL

KIKUSUI ELECTRONICS CORP.

S-750251

Power Requirements of this Product

Power requirements of this product have been changed and the relevant sections of the Operation Manual should be revised accordingly.

(Revision should be applied to items indicated by a check mark)

Input voltage

The input voltage of this product is _____ VAC,
and the voltage range is _____ to _____ VAC. Use the product within this range only.

Input fuse

The rating of this product's input fuse is _____ A, _____ VAC, and _____.

WARNING

- To avoid electrical shock, always disconnect the AC power cable or turn off the switch on the switchboard before attempting to check or replace the fuse.
- Use a fuse element having a shape, rating, and characteristics suitable for this product. The use of a fuse with a different rating or one that short circuits the fuse holder may result in fire, electric shock, or irreparable damage.

AC power cable

The product is provided with AC power cables described below. If the cable has no power plug, attach a power plug or crimp-style terminals to the cable in accordance with the wire colors specified in the drawing.

WARNING

- The attachment of a power plug or crimp-style terminals must be carried out by qualified personnel.

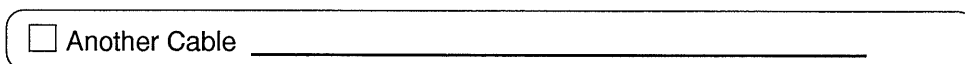
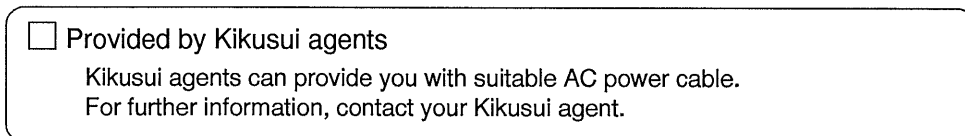
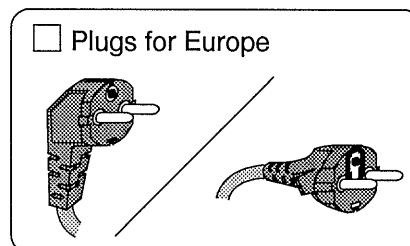
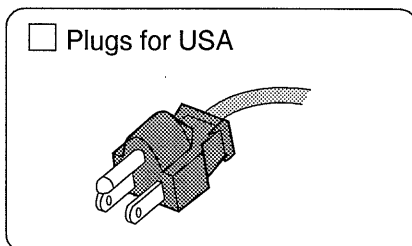
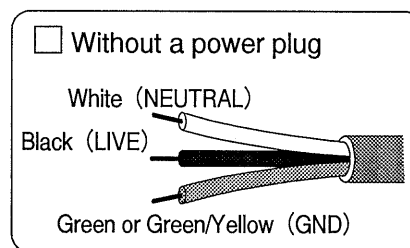
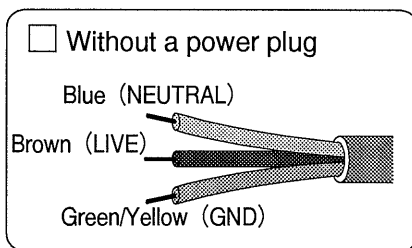

CONTENTS

1.	GENERAL	1
2.	SPECIFICATIONS	2
3.	OPERATING PROCEDURE	3
3 - 1	Explanation of Panel	3
3 - 2	Caution on Operation	5
3 - 3	Operation as DC Power Supply	5
3 - 4	Operation as Amplifier	7
*	CIRCUIT DIAGRAM		

1. GENERAL

The model POW 35-5 consists of a combination of DC amplifier and, positive and negative reference source.

DC output voltage anywhere between 0 volts and ± 35 volts with current anywhere between 0 amperes and ± 5 amperes are available as the regulated bipolar power supply.

Output voltage is continuously variable anywhere between 0 volts and ± 35 volts with a 10-turn helical potentiometer

It is also available as a DC amplifier with a range from DC to approximately 30 kHz by turning the switch on the panel.

Amplifier gain is approximately 10, and an available maximum output is ± 35 volts peak and ± 5 amperes peak.

2. SPECIFICATIONS

Power Requirement	_____V \pm 10%, 50/60 Hz Approximately 450 VA at full load
Dimensions (Maximum)	430 W X 160 H X 300 D mm (431 W X 175 H X 390 D mm)
Weight	Approximately 20 kg
Ambient Temperature	0 ~ 40°C
Accessories	Short-bar 1 Instruction manual 1 Power cord AC-1 1
Terminals	Floating \pm 150 V maximum above chassis ground
<u>Constant Voltage Power Supply</u>	
Voltage	- 35 V ~ + 35 V continuously variable with 10-turn potentiometer
Current	Maximum \pm 5 A
Ripple and Noise	Less than 5 mV rms (At 5 Hz ~ 1 MHz)
Voltage Regulation	Line regulation : Less than \pm 10 mV (Against \pm 10% variation of line voltage) Load regulation : Less than \pm 10 mV (Against 0 ~ 100% variation of load current)
Over Current Protection	Constant voltage-current automatic crossover
<u>Amplifier</u>	
Gain	Approximately 10
Maximum Output	\pm 35 V peak, \pm 5 A peak
Frequency Response	(At maximum amplitude) SLOW 5 kHz (At \pm 3 dB) FAST 30 kHz (At \pm 3 dB)
Distortion	At maximum output (approximately 25 V rms 7 Ω load) FAST at 1 kHz : Less than 0.3%
Voltmeter	\pm 35 V full scale Accuracy \pm 3% of full scale
Amperemeter	\pm 5 A full scale Accuracy \pm 3% of full scale
Cooling	Forced air cooling

3. OPERATING PROCEDURE

3 - 1 Explanation of Panel

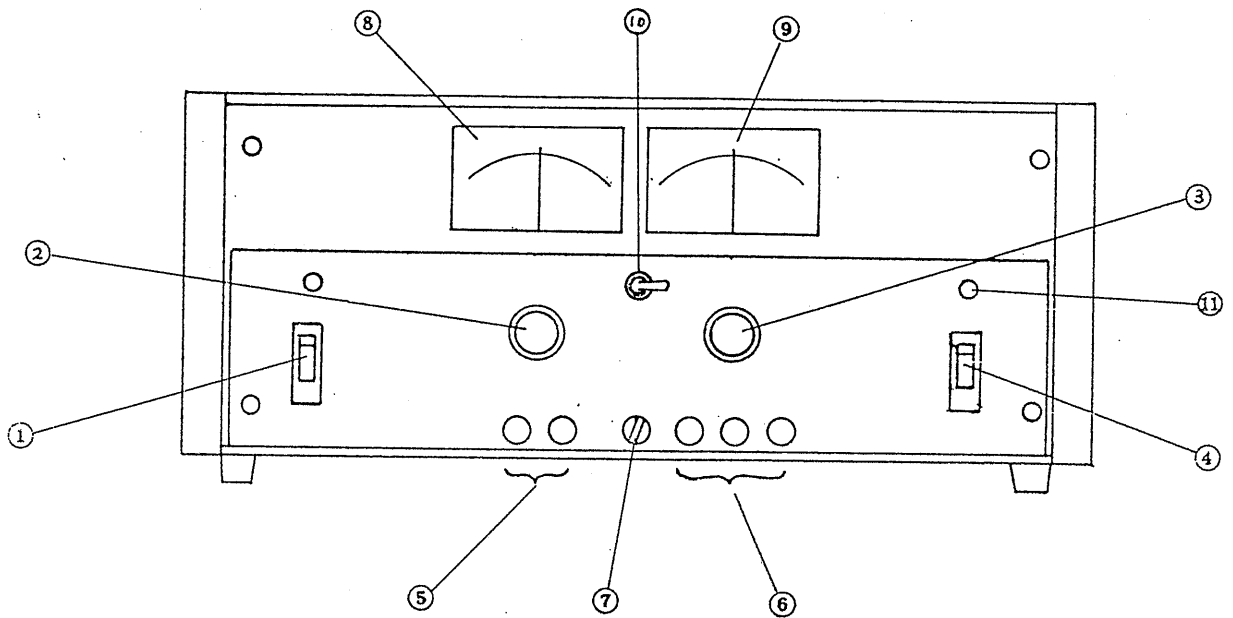

- ① POWER (ON / OFF)
Switch for the input power. Throw it upwards, the power is on.
The LED located above it lights.
- ② POWER SUPPLY AMPLIFIER (SLOW FAST)
Switch for selecting mode of operation. The model can be operated as
a DC regulated power supply or a DC amplifier by switching it.
- ③ Control for output voltage adjustment (10-turn potentiometer).
When operating as an amplifier, the gain increases by rotating
clockwise. When operating as a power supply, the output voltage
varies continuously from - 35 volts to + 35 volts by rotating clockwise.

- ④ OUTPUT (ON / OFF)
Stand-by switch for the output. Throw it upwards, the output supplies on the output terminals.
- ⑤ INPUT (H L)
Terminals provided the input signal for operating as an amplifier. Connect the earth side of the input signal to the terminal L. They are floated from the panel, and terminal L is joined to the output terminal L ⑥ .
- ⑥ OUTPUT (H L GND)
Terminals for the output. The terminal H and the terminal L are floated from the chassis, and the output terminal L is connected to the input terminal L ⑤ . GND terminal is directly connected to the panel. When it is required to connect the output terminal to the panel, connect the terminal L to it.
- ⑦ ZERO
Semi-fixed resistor for DC balance adjustment of output voltage, when operating as an amplifier. Adjust the control ⑦ such that DC output voltage is zero with no signal applied to the input terminal. When operating as a power supply, this is a fine control of the output voltage.
- ⑧ Ampere meter indicating output current. When the current flows from the terminal H to the terminal L, it indicates positive direction.
- ⑨ Meter indicating DC output voltage.
- ⑩ METER (ON OFF)
Switch for meter. Meter circuit can be turned off from the output by switching to the OFF position, when a pointer is vibrated by the signal less than a few Hz. The voltmeter and the ampere meter are turned on or off together.

⑪ OVERLOAD

Overload indicating LED of output. The LED lights, when the peak output current exceeds approximately positive or negative 5.2 A. When output current is AC, brightness of the LED is different with the waveform.

3 - 2 Caution on Operation

Take care of the following explanations on operation.

(1) Supply line voltage

Operate within a range of 100 V \pm 10% with 48 Hz ~ 62 Hz.

(2) Installed place

The place exposed to heat from near source.

The place where the ambient temperature exceeds 0 ~ 40°C.

The much humid or dusty place.

The place where the circulation of the air is few.

Do not operate at the place explained above.

It disturbs distinctly heat radiation effect that this instrument is laid, something is put on it or something is put near the vent of the fan, and it may cause the damage.

3 - 3 Operation as DC Power Supply

When operating as a regulated DC power supply, set the knob ② to POWER SUPPLY position. The output voltage is continuously variable from - 35 volts to + 35 volts with the knob AMPLITUDE ③.

The knob 3 is 10-turn potentiometer, and 0 volts output is obtained at the approximate center position. It is continuously available from the above position up to + 35 volts with CW rotation or up to - 35 volts with CCW rotation.

Output current is available up to \pm 5 amperes.

Over-current protecting circuit operates at approximate 5.2 amperes. Then, output voltage reduces, and overload indicating LED ⑪ lights.

S-750257

The model POW does not only deliver current to external load, but also current from external power source can flow into it.

The external source A is connected to the POW through the resistor R as shown in Fig. 3 - 2. When the output voltage is higher than the output voltage of POW, the current flows in the arrow direction. When it is lower than the output voltage of POW, the current flows in the inverse arrow direction.

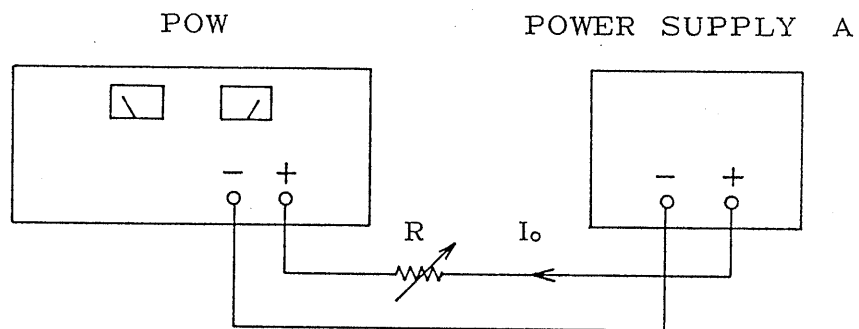

Fig. 3 - 2

In such an operation, maximum current of POW is restricted to the value lower than generally using. Maximum allowable output current $I_o \text{ max}$ is shown as follows.

$$|I_o \text{ max}| = \frac{300}{|60 + E_o|} \quad (\text{A})$$

In such a case, over current protecting circuit may operate, and overload indicating LED may light. However, the output voltage E does not reduce.

When unipolar output is required (inverse polar voltage is never produced to the output.), POW should be used as an amplifier with proper DC input voltage.

When more fine adjustment of output voltage is desired, use POW as an amplifier. But the variable range of output voltage is narrow.

For example, output voltage between 0 volts and + 10 volts by 10-turn potentiometer of POW, when + 1 volt input voltage is connected to the input terminal (It is possible to adjust minutely about zero volts by the semi-fixed resistor ZERO on the panel.

3 - 4 Operation as Amplifier

When POW is operated as a DC amplifier, set the knob ② to AMPLIFIER (SLOW or FAST) position. When input signal is applied to the input terminal ⑤, the amplified signal is obtained on the output terminal ⑥ .

Amplitude increases by rotating clockwise the AMPLITUDE knob ③, it becomes zero at fully counter clockwise position. It is continuously variable up to approximately 10.

Maximum output is ± 35 V_{peak} and ± 5 A_{peak} (at rms value of sinewave, approximately 25 V and 3.5 A). Over current protecting circuit operates at approximately ± 5.2 A peak. It is the same value as operation as amplifier.

Brightness of the overload indicating LED is varied by waveform of output current, and it increases when the period of over current within one cycle becomes long (It becomes maximum at DC.).

Maximum input without distortion is limited to approximately ± 7 V peak by input protecting circuit. When the gain is less than approximately 5, maximum output without distortion is also limited.

For example, when output of ± 35 V peak with the gain 1 is required, overall gain should be adjusted to 1 with external attenuator by inserting attenuator in front of the input terminal.

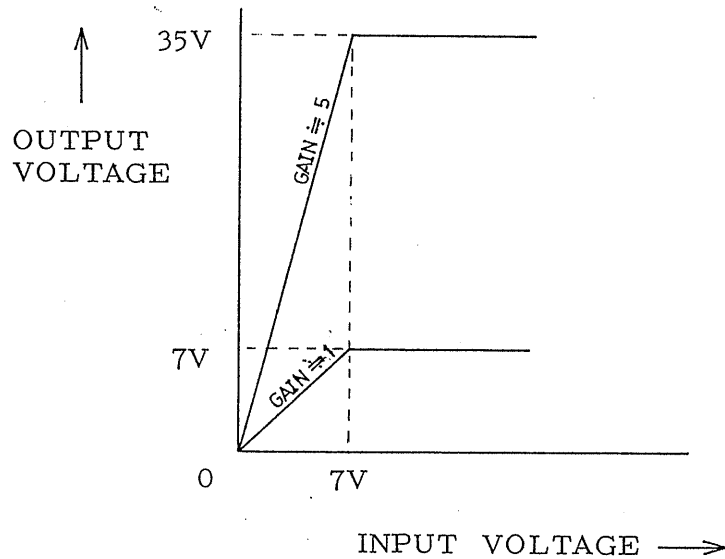

SLOW and FAST

When using as an amplifier, cut off frequency is approximately 5 kHz at the SLOW position of the knob (2) or 30 kHz at FAST position of the knob (2).

When the capacitance of load is more than 0.001 μ F, POW may be unstable at FAST position. But it is stable at the SLOW position. (Use the function, when responsive speed is negligible.) It must be used, when capacitance across output terminals is too much with too long cable or others.

ZERO

The semi-fixed resistor ZERO (7) on the front panel is for zero volts adjustment of output voltage, and its variable range is ± 150 mV.

Short the input terminal, and adjust it for zero reading on high sensitive voltmeter.

Zero adjustment is affected for input offset current of POW and the resistance connected to the input terminal without signal.

When POW is operated as a DC power supply, the zero adjustment is used for the fine adjustment of output voltage.

Meter

Both voltmeter and amperemeter are DC meter, and they indicate little for the signal more than approximately 20 Hz. When input signal is approximately 1 Hz, the pointer of meter is violently vibrated. In such a case, turn the METER (ON OFF) switch (10) to the OFF position.